

One-side coated woodfree flexible packaging paper

LumiFlex is a one-side-coated, wood-free flexible packaging paper.

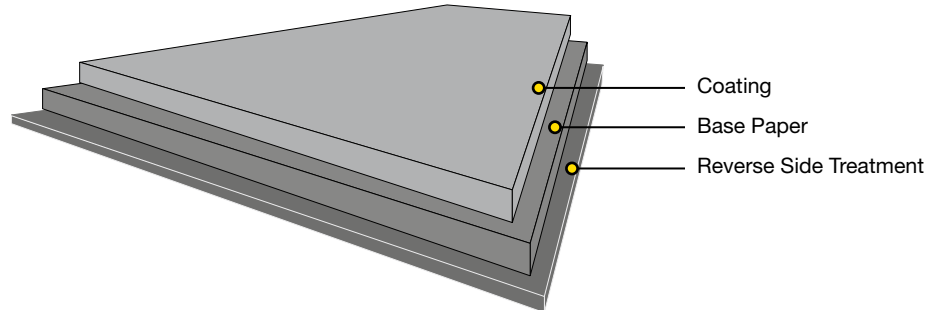

Issued: 07.2017
Cancels: 10.2016

Technical specification

Property / Unit	Tolerance										Standards
	±4%	60	70	80	90	95	97	110	120	140	
Grammage, g/m ²	±4%	60	70	80	90	95	97	110	120	140	ISO 536
Thickness, µm	±5	55	64	73	83	86	89	101	110	130	ISO 534
Brightness D65/10, %, CS	±3	84	86	86	86	86	86	86	86	86	ISO 2470-2
Tensile strength, kN/m, MD	±1.3	5.0	5.6	6.2	6.8	7.1	7.2	7.3	7.3	7.4	ISO 1924-3
Tearing resistance, mN, CD	±100	350	450	500	600	620	650	700	850	1000	ISO 1974
Surface Smoothness, PPS 10, µm, CS	±0.3	1.10	1.00	1.00	1.00	1.00	1.00	1.00	1.00	1.00	ISO 8791-4
Gloss 75°, %, CS	±3	60	62	62	62	62	62	62	62	62	ISO 8254-1
Opacity, %	±3	79	86	88	90	91	92	93	94	95	ISO 2471

No OBA added.

One-side coated woodfree flexible packaging paper

Certificates

Quality management ISO 9001
 Environmental management ISO 14001
 Product safety ISO 22000
 Health and safety OHSAS 18001
 Energy management ISO 50001
 EU Ecolabel registration SE/011/006, the ecological criteria for Copying and Graphic Paper 2011/333/EY, L149/12, 8.6.2011



FSC and PEFC certified paper available upon request.



Paper is recyclable

Key characteristics and main enduses

LumiFlex is a sustainable paper used in various food packaging applications in direct food contact, and in yoghurt banderoles, wrappers, bags and pouches and in metallizing. LumiFlex is suitable for rotogravure, flexographic or offset printing.

Storage recommendations

For optimal printing results, the moisture proof wrapping should not be removed until the paper has reached the temperature of the press room.

Pallet/Reel Weight (kg)	Difference in temperature between paper and press room (press room temp. approx. 20°C)		
	10°C	20°C	30°C
400 kg	2 days	2 days	3 days
800 kg	2 days	3 days	4 days
1200 kg	2 days	4 days	5 days

The product properties, according to the specifications, are guaranteed for 12 months after the production date. In order to ensure product safety, the product must be well wrapped and stored indoors, sheltered from rain and snow. The recommended storage conditions are 50-55% relative humidity and 20-23° C.

